

**I**NSTALLATION  
**O**PERATION  
**M**AINTENANCE  
FOR  
FORGED / CAST GATE VALVE



**SAKTHI INDUSTRIES**

**CHENNAI 600 098**



---

## PREFACE

This Manual applies to the Excel Gate valves manually operated made of Cast carbon steel Gr.WCB only.

To ensure safe and trouble free function and performance, please read all the contents of this manual before handling, transportation, mounting, operation and maintenance of valves. Keep this manual in convenient place for your valve operator's easy access

Caution indicates a "potentially hazardous situation which if not avoided could result in minor or major injuries and loss of life, properties etc."

This manual covers the normal usage of the product. Technical data and instructions for operation, maintenance and inspection of the product are prepared in consideration of safety. However they are good only to cover typical applications and provided as a general guideline to users. If technical assistance is required, contact manufacturer's Executive.

The illustrations given in this manual do not introduce all details. If more detailed data is needed, refer to the relevant valve assembly drawings.

Note: Any information this operation provided in this operation manual is subject to revision at any time without notice. This edition cancels all previous issues.



---

## 1.0 INTRODUCTION

When properly installed in applications for which they were designed, EXCEL VALVES will give long reliable service. This instruction is only a guide for installation and operation on standard service and cover general maintenance and minor repairs.

### Note:

- We recommend that this entire document be read prior to proceeding with any installation or repair. Take no responsibility for damage or injury to people, Property or equipment. It is the sole responsibility of the user to ensure only specially trained valve repair experts perform repairs under the supervision of a qualified supervisor.

## 1.1 RESPONSIBILITY FOR VALVE APPLICATION:

The User is responsible for ordering the correct valves. The user is responsible for ensuring valves are selected and installed in conformance with the current pressure rating and design temperature requirements. Prior to installation, the valves and nameplates should be checked for proper identification to ensure the valve is of the proper type, material and is of a suitable pressure class and temperature rating to satisfy the requirements of the service application.

### CAUTION:

- Do not use valves in applications where either the pressure or temperature is higher than the allowable working values. Also valves should not be used in service media if not compatible with the valve material of construction, as this will cause chemical attacks, leakage and valve failure.

## 1.2 RECEIVING INSPECTION AND HANDLING:

Valves should be inspected upon receipt to ensure:

- \* Conformance with all purchase order requirements.
- \* Correct type, pressure class, size, body and trim materials and end connections.
- \* Any damage caused during shipping and handling to end connections, hand wheel or stem.

---

Excel Brand IBR/ Non IBR Globe, Gate, Bellow Seal Valves,  
Control Valves, Pressure regulating valves, NRV, Y Strainers, Ball Valves

# IOM

- **INSTALLATION**
- **OPERATION**
- **MAINTENANCE**



---

**CAUTION:**

- The user is advised that specifying an incorrect valve for application may result in injuries or property damage. Selecting the correct valve type, rating, material and connections, in conformance with the required performance requirements is important for proper application and is the sole responsibility of the user.

## 1.4 SAFETY INFORMATION:

The following general safety information should be taken in account in addition to the specific warnings and cautions specified in this manual. They are recommended precautions that must be understood and applied during operation and maintenance of the equipment covered in this I.O.M.

**CAUTION:**

- Never attempt to disassemble a valve while there is pressure in the line. Ensure both upstream and downstream pressures are removed. Disassemble with caution in case all pressures are not relieved. Even when replacing stem packing, caution is necessary to avoid possible injury.
- To prevent valve bending, damage, inefficient operation, or early maintenance problems, support piping on each side of the valve. When handling gases/fluids that could cause damage to human health, the environment or property, the necessary safety precautions to prevent risk must be taken.
- A valve is a pressurised mechanism containing energised fluids under pressure and consequently should be handled with appropriate care.
- Valve surface temperature may be dangerously too hot or too cold for skin contact. Upon disassembly, attention should be paid to the possibility of releasing dangerous and or ignitable accumulated fluids. Ensure adequate ventilation is available for service.

## 1.5 CONSTRUCTION:

The following is a typical assembled of an excel wedge gate valve. The number of parts will slightly vary in each size and class but the principal components are same as per figure.

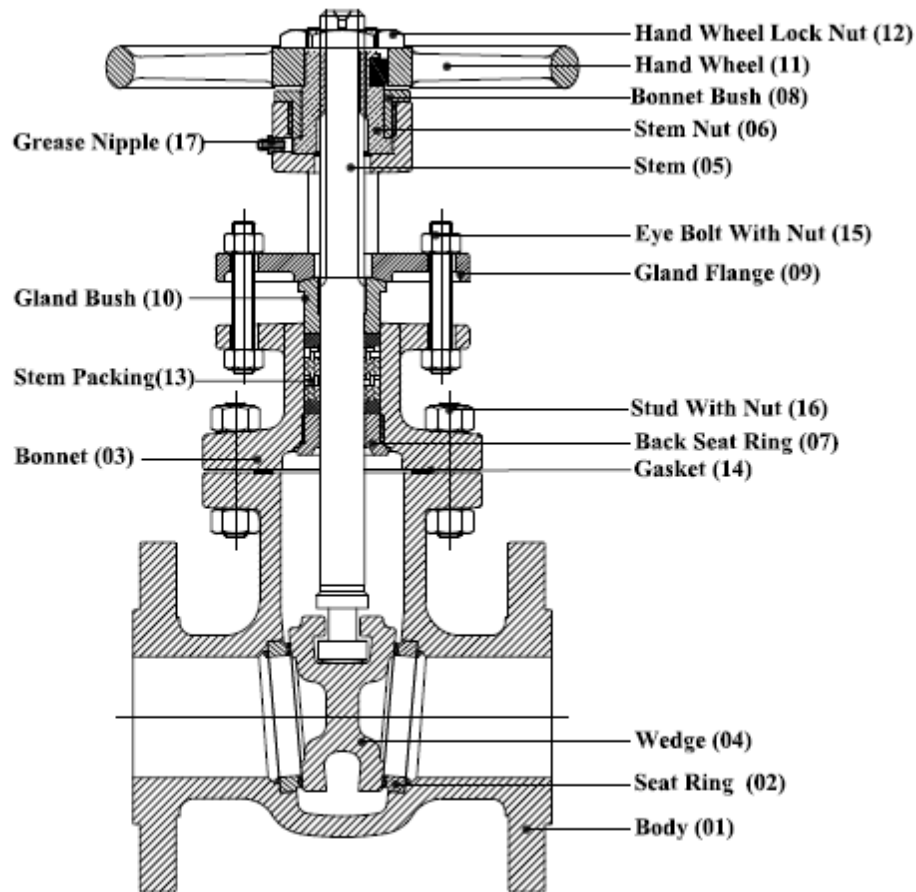

Fig.: 1.1 General Sectional Drawing- Assembled

(The above is indicative only; design depends on size, class and trims etc., Refer to as-built drawing)



---

## 2.0 INSTALLATION:

Gate valves are usually bi-directional, and therefore may be installed in either direction. In some other cases, gate valves may be uni-directional, in which case the direction of flow will be indicated on the valve.

Preparation for installation:

- Remove protective end caps or plugs and inspect valve ends for damage to threads, weld ends or flange faces
- Thoroughly clean adjacent piping systems to remove any foreign material that could cause damage to seating surfaces during valve operation.
- Verify that the space available for installation is adequate to allow the valve to be installed and to be operated.

## 2.1 END CONNECTIONS:

### 2.1.1 Threaded Ends:

Check the condition of thread on mating pipe. Apply joint compound to the male end of joint only. This will prevent compound from entering the valve flow path.

### 2.1.2 Flanged Ends:

Check to see that mating flanges are dimensionally compatible with the flanges on the valve body ensures sealing surfaces are free of debris. Install the correct studs and nuts for the application and place the gasket between the flange facings.

Caution: Stud nuts should be tightened in an opposing criss-cross pattern in equal increments to ensure even gasket compression

## 2.1.3 Socket Weld Ends:

Remove all debris, grease, oil, paint, etc., from the pipe that is to be welded into the valve and from the valve end connections. Insert the pipe into the valve end connection until it bottoms out in the socket weld bore. Withdraw the pipe 1/16" so that a gap remains between the pipe and the bottom of the socket weld bore to prevent cracks (ASME B16.11). Tack the pipe into the valve and complete the fillet weld.

## 3.0 Operation:

Gate Valves should only be used in the fully open or fully closed operation.

Note: Gate Valves should not be left in the fully back seated position under normal operating conditions. The packing may dry out under these conditions and leak as the valve is closed. A cooling valve may leak through the gland when opened to hot fluid, wait before tightening the packing as the problem may go away.

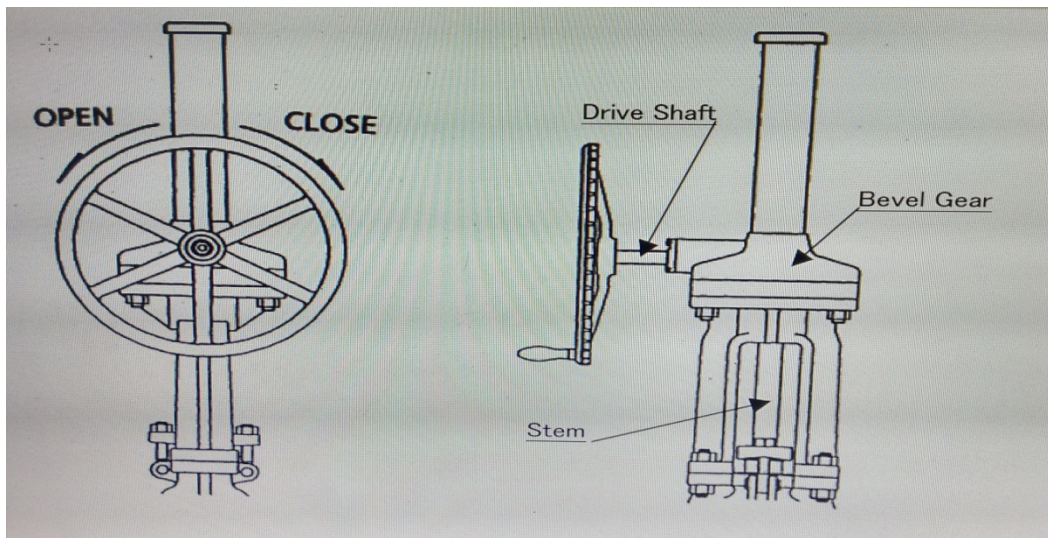

Fig.: 3.1 Gear Operated Gate Valve

**Gear Operations:** Most valves, which are located in an accessible environment, are operated by a manual hand-wheel mounted directly on top of the valve. When the valve size or differential pressure is so great that the hand wheel size cannot keep the operating hand wheel pull within customer reasonable limits, then a bevel gear should be mounted on the top-works. In addition, many customers require remote operation or operating times that are not possible with manual hand wheels, in this case Electric Motor Operators (EMO's) can be used.

## 4.0 Maintenance:

Proper safety equipment and apparel should be worn when preparing to service a valve. Observe the following general warnings:

**Packing:** Special care is to be placed in the tightening of the gland nuts during installation, to ensure the proper packing adjustment and functionality. During the packing life cycle, normal and routine maintenance of the packing arrangement must be administered. Over tightening will cause the packing to fail prematurely as well as increasing the force required to operate the valve.

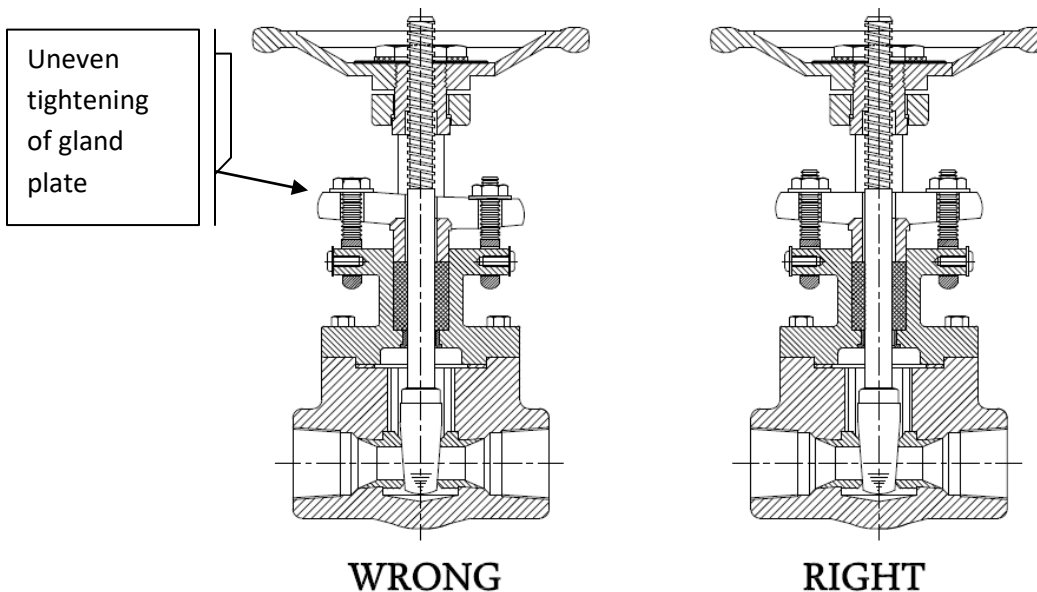

Fig.: Tightening of gland plate nuts



# IOM

- INSTALLATION
- OPERATION
- MAINTENANCE



---

It is not recommended to repack gland under pressure. So back seating the valve and attempting to repack under pressure is hazardous and is not recommended. Rather than attempting to repack under pressure, it is preferable to use the backseat to control the stem leakage until shutdown of the line provides safe repacking conditions.

Prior to replacing the packing rings, remove all pressure from the valve must be tightly back seated. However, it is not recommended as this will not ensure complete safety and should not be attempted. If the backseat faces have been damaged by foreign material the backseat may leak into the packing chamber

**Gear:** The gear or electric operator itself should never require disassembly and it is recommended that this be done only by the operator manufacturer. If it becomes necessary to disassemble the valve, the operator assembly must be removed first.

## Periodic Inspections:

- The Valve stem packing should be inspected monthly, if the stem packing shows signs of leakage. Simply tighten nuts to compress the packing. Do not over tighten the adjusting nuts as this will make operation of the valve more difficult. If after tightening the adjustment nuts to their fullest to extent, the leakage does not stop, it is then necessary to replace the stem packing. It is not recommended that additional packing rings be added to the stuffing box as this may cause damage to the stem sealing system.
- The Lubrication of the yoke nuts should be inspected monthly. A high pressure grease gun should be used for valves supplied with ball type grease fittings.
- Bonnet bolt tension should be checked periodically when valves are used in high temperature applications where creep may occur. Although leaks through bonnet ring or spiral gaskets are rare, erosion or corrosion could cause bonnet seal to fail. In the cases, a new gasket is required.
- With problematic service applications it is recommended that the valve be periodically at least partially stroked to ensure valve functions and to ensure there is no product deposits entering into the seat or stem area which may render operating more difficult. Duration depends on service, criticality, etc., However, it also must be factored in that if there are impurities or particulates in the line which are likely to be built up in the seat area, each operation could reduce seat life proportionately.